

# Panasonic



## Newly Developed super 35mm MOS SENSOR

---

REFERENCE MANUAL



July, 2015

Revision	Date	Explanation
Rev.1.2	July, 2015	First Edition

## Summary

Panasonic recently developed the "VARICAM 35", a modular camera system comprised of a camera "head" module (AU-V35C1G) and a recorder module (AU-VREC1G). The "VARICAM35" camera is equipped with a newly developed super35mm MOS sensor, and records using the "AVC-ULTRA" family of Video CODECs for 4K / UHD / 2K and HD recordings.

The new super 35mm size MOS sensor in the "VARICAM 35" has very wide color gamut, and an effective 8.9 million pixels. Yet it easily achieves a wide dynamic range of 14 + stops. In addition, it provides the characteristic shallow depth of field of super 35mm cinema format, combined with the required high resolution for native 4K recording.

This document explains the Panasonic newly developed s35mm imager technology and MOS Sensor developed for the high-performance "VARICAM 35" camera system.

### 1. Introduction

The digital video production process is quite common now in the video production industry because of some advantages such as efficiency of production workflows, Video quality and CG workflows. The type and number of digital video camera available on the market has also greatly expanded. The optical system for the camera is required to be the same as that of a super35mm camera, which features a single large-sized sensor, much different to the conventional 2/3" 3 imager / prism EFP video camera. Moreover, in order to meet the various demands of video producers, namely; wide latitude (dynamic range), high sensitivity, and high-frame rate capture are also required. Initially the large format cameras were of the HD or 2K (2048 (H) × 1080 (V)) resolution class, now various 4K (4096 (H) × 2160 (V)) cameras are available and in use.

With this camera market growing, Panasonic decided to develop a 4K camera / recorder, to be known as the "VARICAM 35". In developing this camera, it was critically important to realize true 4K high-resolution, wide dynamic range and high-frame rate recording, plus the expected features like VFR (variable frame rate) recording, VFR was one of the strengths of the earlier Panasonic VariCam 2/3" cameras. To achieve this, Panasonic has developed a MOS sensor specifically designed to match the newly designed super35mm 4k optics. The following describes the new technology that has been integrated in the new sensor.

## 2. The Design Criteria for the new Image Sensor.

As the image sensor used in this camera of the video production field applications, the following requirements were considered the most important points, in order to meet the various requirement from video creators to represent their creative ideas.

- (1) Wide dynamic range to achieve the 14 stops and more.
- (2) High Sensitivity to allow shooting in low light.
- (3) VFR (Variable Frame Rate) high-speed imaging

With such a requirement, in order to achieve at a high pixel count for 4K signal, Panasonic developed the new technologies for image sensors by merging the experience from our semiconductor technology group, with that of the high-quality camera system design tradition that has been cultivated for many years for the broadcast and professional video industry.

In the next section, the detail of the introduced technologies to achieve the superb performance and the unique functions will be described.

## 3. New technology of the new image sensor

The specification of newly developed image sensor is shown in Table 3-1. When compared with the HD (or 2K) conventional image sensor with the same optical size., As UHD/ 4k imagers have twice the horizontal and vertical number of pixels, the pixel area will be very small as compared to a n HD 35mm imager, as  $\frac{1}{4}$  of the effective size. Therefore, it is necessary to generate a four times performance improvement for 4K, to achieve equivalent performance at 2K

Further, imager clocking speeds are proportional to the increase in the number of vertical pixel columns, so in order to achieve the same frame rate, the operating speed is also required to be doubled for the pixel read speed and ADC.

This chapter will describe the details of the technology developed and implemented to achieve the desired performance at 4k levels.

Subject	Specification
Image sensor size ( effective area)	26.688 (H) mm ×14.184 (V) mm
Effective pixels	4448 (H) × 2308(V)
Total Pixels	5160(H) × 2408 (V)
Size of Pixel	6.0 (H) μm × 6.0 (V) μm
Color Filter pattern	R,G,B Bayer Pattern

Table 3-1. Specification of Image Sensor

**3-1. High Dynamic Range and High Sensitivity technology**

Figure 3-1-1 shows the electric potential distribution of the high-capacity photodiodes of this image sensor. By modifying the photosite well design, the charge capacity of the photodiode is boosted 1.3 times over a conventional well. Larger well capacity means more charge, which equates to higher dynamic range before well saturation.

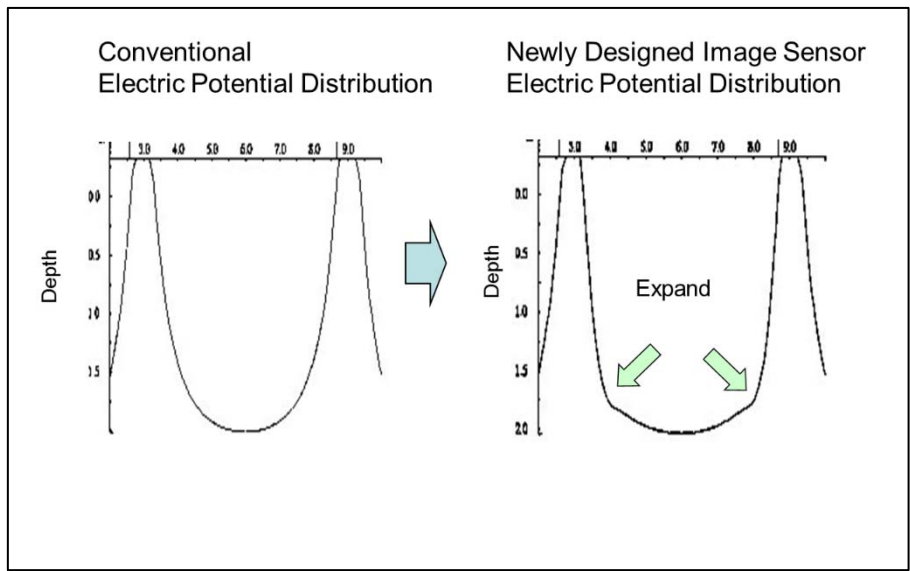

Fig. 3-1-1 High capacity Photodiodes

In addition, high sensitivity is one aspect of the imager design vigorously pursued. The improvement of the light-harvesting performance was accomplished by optimizing the curvature of the on-chip lens that forms on top of the photodiode, and also the silicon’s photoelectric conversion efficiency.

With the above technology, even though pixel area has been reduced by 75%, the high saturation characteristics and the high sensitivity are maintained. The VariCam35 s35mm imager has achieved industry's highest level of 14 + stops for dynamic range in amongst comparative 4K cameras.

### 3-2. Dual Native ISO

Figure 3-2-1 shows the conceptual diagram of Dual Native ISO and the conventional one. The relationship of ISO sensitivity and the noise of the new system is explained in Figure 3-2-2.

In a conventional imager / system, the ISO number is increased by increasing the gain of the gain amplifier. Therefore, in proportion with ISO number, it is also amplified the noise, the S/N ratio is deteriorated as a result. This is the traditional “gain-up” ISO boosting technique.

In the new s35mm Panasonic image sensor, each imager pixel has an integral ISO (sensitivity) switching circuit. This ISO switch mode uses changes in the charge to voltage conversion processing of each pixel. The choices are native ISO 800 and native ISO 5000. ISO 5000 is about 6 times the standard sensitivity of ISO 800 (about 2.6stops), however and importantly as no electronic gain is used in this ISO switching process, the noise performance of the camera at ISO5000 is very similar to that of ISO800. (Measured SN/R differences are only about 1dB). Shown in Figure 3-2-2.

Photos 3-2 shows gray scale chart of a “conventional camera system” (gain added to produce an effective ISO of 5000). Compare that with the image from the Dual Native ISO technology operating at ISO5000. As is apparent from the photographs, by using Dual Native ISO technology, the noise performance at ISO 5000 is only slight worse than that of native ISO800. This huge increase in ISO800 to 5000 equates to having two native film stocks in the camera. The obvious benefits of ISO 5000 are the ability to shoot with no added electronic gain in very low light levels and obtain remarkable imagery that well surpasses the human eye’s ability to see at those light levels. Native ISO 5000 provides for huge savings in necessary lighting levels, as it is possible to shoot at levels under 2 foot candles.

With the need to shoot sports events in UHD/4k, the conundrum of 4k s35mm versus B4 2/3” arises. B4 2/3” EFP lenses provide the necessary depth of field, and the large zoom ratios for modern sports production. S35mm 4k cameras usually use s35mm large format imagers; those limit zoom size / ratio and an inherent shallow depth of field. The compromise often

used is to use the B4-mount lens with some form of B4 2/3" to PL / s35mm optical adaptor. Although less than ideal, this process does provide the much needed zoom capability, but at a cost of around 2.5 stops of light.

Because the difference in optical image format sizes, the sensitivity of the camera system will decrease 2.5 stops.

Interestingly, that 2.5 stops of light loss, just happens to coincide with the 800 / 5000 ISO relationship of the VariCam 35. So by using a 2/3" B4 to PL s35mm optical adaptor that enables large 2/3" zoom lenses, the use of ISO 5000 overcomes the 2.5 stops of light loss in the large format conversion for 2/3" to s35mm, this native ISO process has no added noise, thus comparable performance is maintained.

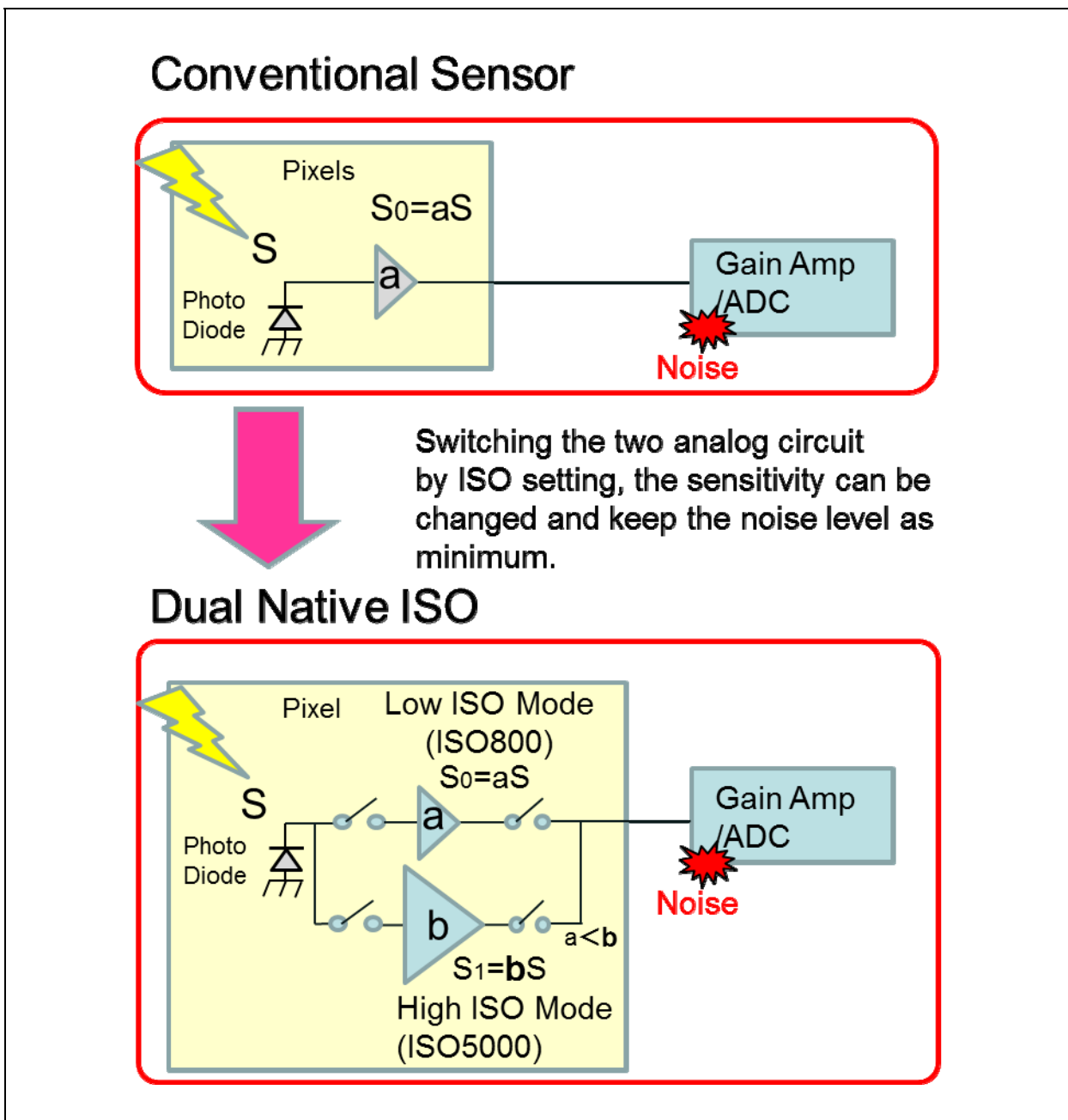

Figure 3-2-1. Conceptual Diagram of Dual Native ISO

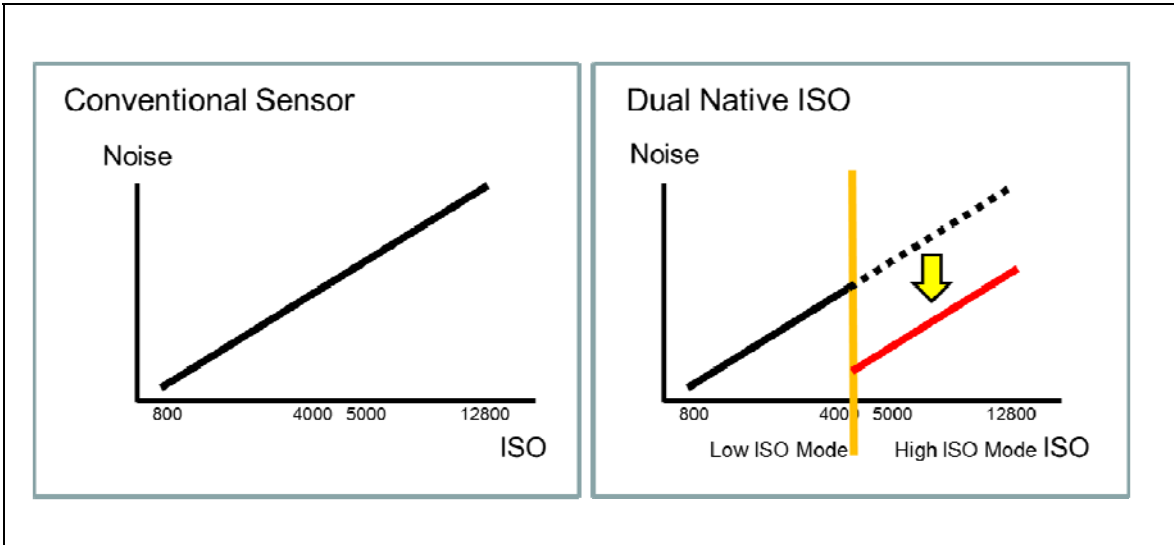

Figure 3-2-2. Relationship of ISO and Noise level with Dual Native ISO

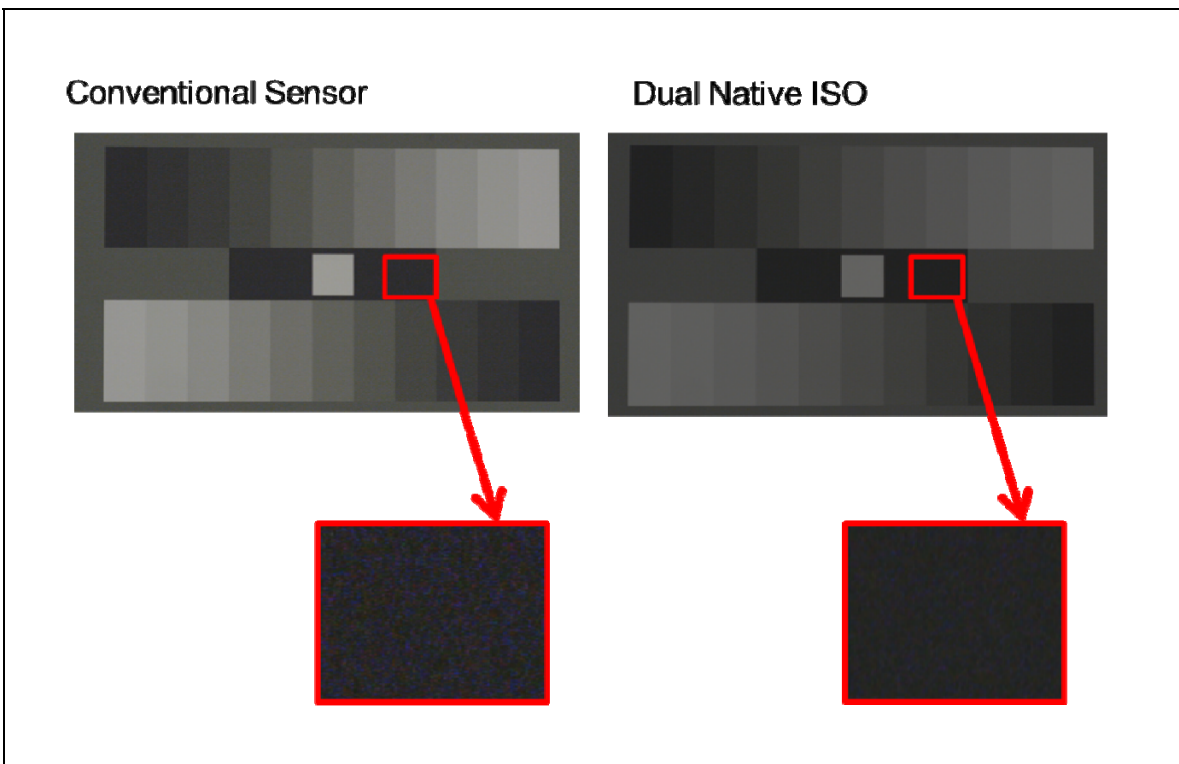

Photo 3-2. Noise level at Gray Scale chart with Dual Native ISO (ISO5000)



### 3-3. New technology to achieve high-speed imager clock driving.

It shows a schematic diagram of the image sensor in Figure 3-3-1.

In order to realize high-speed image capture, the following new technologies are implemented.

- (1) A pipeline processing system for vertical pixel reading and horizontal pixel reading.
- (2) Reduction of the parasitic capacitance by dividing the signal line to an up / down division of the pixel array. Also parallelization of the pixel array signal line.
- (3) Speed up of driving transistors for the signal in the pixel array.
- (4) Ultra-high-speed digital output circuit using cutting-edge micro-process semiconductors.

The technology once implemented means that frame rate can be doubled over more conventional 4k imagers, and the reduction in the pixel read / xtalk succeeded in suppressing the noise by 1/2 or more. Thereby making it possible to achieve the goal of a wide dynamic range, high speed, dual ISO, 4k native MOS imager capable of 4k 120fps full imager operation.

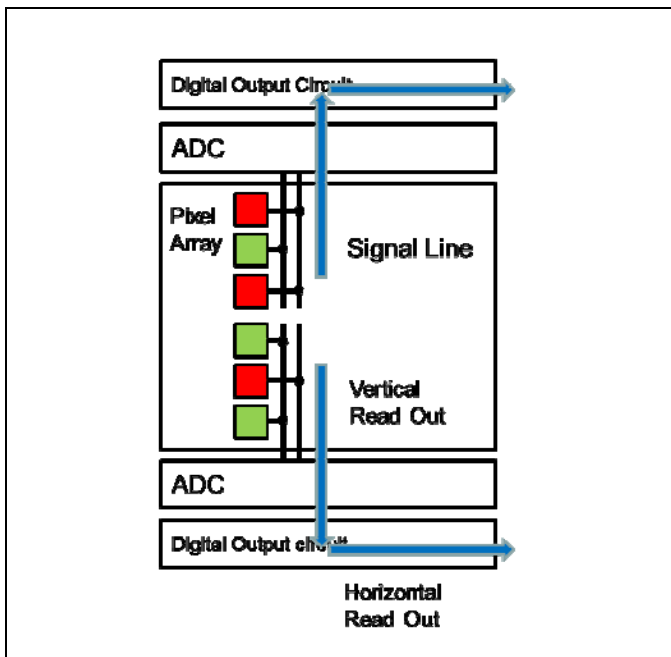

Figure 3-3-1. Conceptual Diagram of up/down division signal reading

### 3-4 Pixel structure for the surround display (look-around feature) on Viewfinder

Figure 3-4-1 shows the number of pixels on the image sensor. The effective number of pixels for recording video are 4096 (H) × 2160 (V). In addition to the active imaging area, there are the extra pixels, when these extra (surround pixels are read) they provide a “look-around” or wide view of the camera’s field of view. Although not used when recording 4k content, those extra “look-around” pixels provide the equivalent of an optical viewfinder, giving the ability to see things approaching the camera active field of view. These are items such as microphone booms, dollies, DIT carts, and the plethora of production paraphernalia that you do not want in the shot. The ability to see what is about to enter the shot is a useful and time saving one.

By read out from these extra pixels, and displaying the image including the extra pixels only in the VF and VF output, the photographer can check before an obstacle such as a microphone enters the shot. In the VARICAM 35, the total capturing area including the surrounded extra is 4384 (H) × 2234 (V).

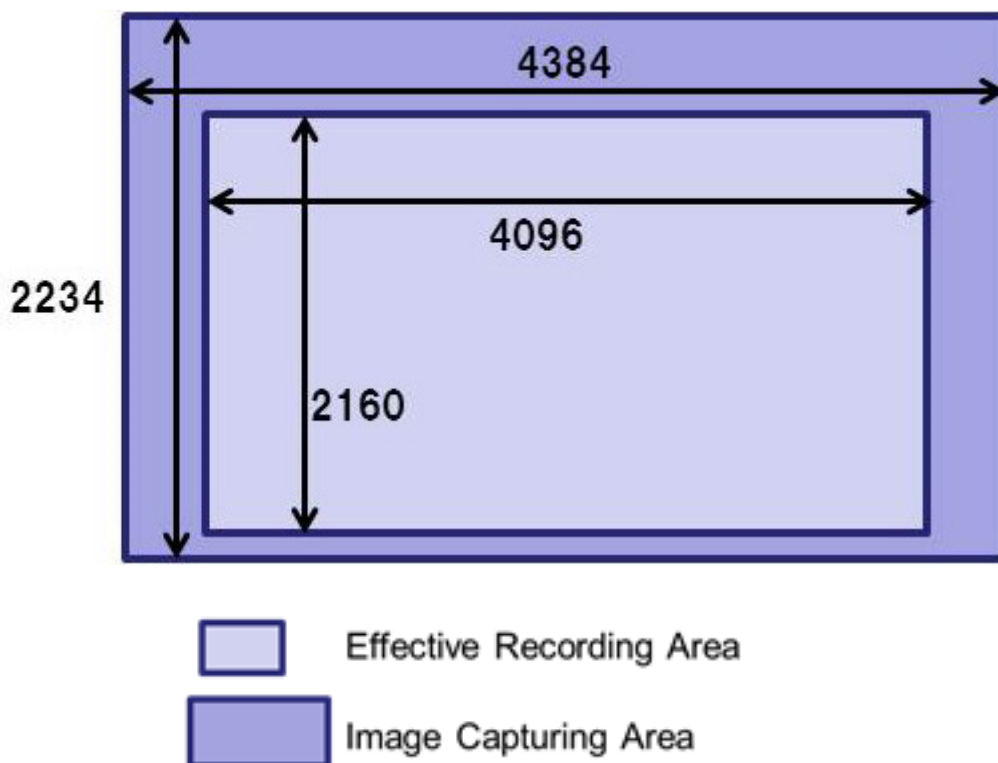

Figure 3-4-1. Pixels of Image Sensor

## 4. Consideration of global shutter

On the MOS image sensor, normally, unlike the CCD, the exposure time will be shifted for each scanning line, the result is a so-called the rolling shutter structure. Recently, in order to avoid the focal plane skew distortion on moving objects, a few MOS image sensors with global shutter structure have been commercialized.

However, this global shutter structure has a number of side effects, further and importantly the basic performance (S/N, Dynamic Range, etc.) of the imager deteriorates if a Global Shutter is implemented.

The current trend of technological development in image sensors is to maintain or improve imager performance and prevent unwanted side effects. This method can realize high-speed image capture, while maintaining the high dynamic range performance and, at the same time reduce motion skew by fast (often asymmetric readout of imager data, to reduce the focal plane distortion.

### 4-1. The current structure of an implemented global shutter

This shows the structure of a single pixel configuration of an image sensor which uses a global shutter, and that of an imager with a traditional rolling shutter, both of these technologies are currently commercialized. Figure 4-1-1

The global shutter function is realized by adding a transistor to reset the pixel, as shown in the 4.1.1. (FET is in RED)

Such an implementation of a GS has many negative effects, one is the elimination of CDS (Correlated Double Sampling) This operation is long implemented and widely used noise reduction processing, so if the GS is implemented, the lack of CDS means noise levels increase. Allied with the noise increase, the extra pixel structure ( a FET and storage capacitor) eat away at the precious “fill factor” of the active pixel, simply put, the extra circuitry blocks some of the needed light and makes the active image sensitive area smaller, thus less sensitive and a lower dynamic range.

Depending upon how GS was implemented other negative aspects can intrude, storage capacitor variations can introduce fixed pattern noise, signal leakage on the analogue storage can result in streaking and pixel to pixel leakage.

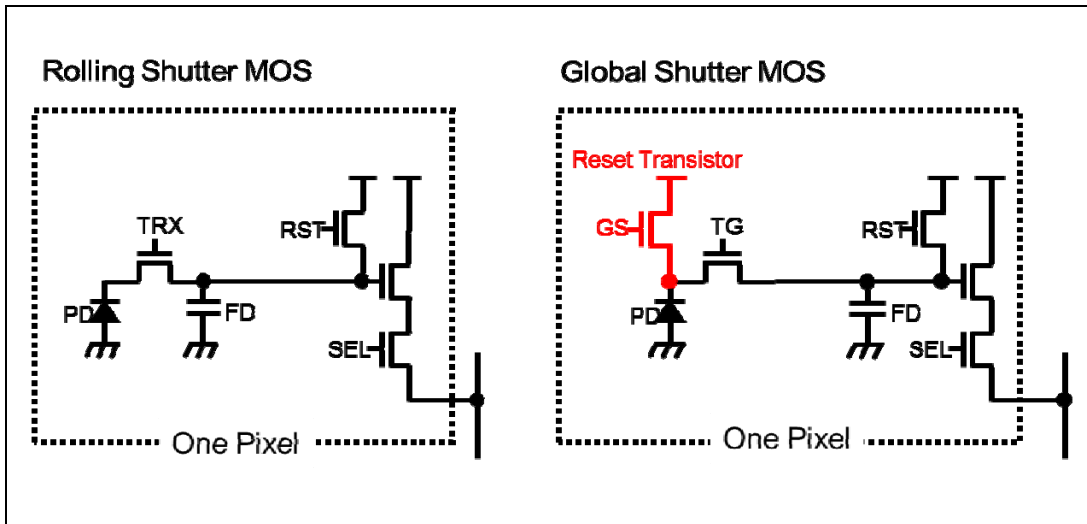

Figure 4-1-1. Pixel structure of Rolling Shutter and Global shutter

#### 4-2. Side effects of global shutter structure

Figure 4-2-1, shows the negative symptoms due to global shutter in Figure 4-2-2.

In the present global shutter situation, it configures the analog memory (a capacitor) in the pixel, and charge the electrons in this capacitor. Therefore, when shooting a high luminance object, leakage of electric charge from the photodiode overflowing will be in a capacitor, or a defect due to photoelectric conversion at the capacitor itself occurs. Specifically, Figure 4-2-1, and Figure 4-2-2 are examples of bad symptoms.

Figure 4-2-1 is a false signal that occurs when a bright object is moved to the left and right, a phenomenon similar to the residual image which is generated in the image pickup tube. Usually, residual image by the imaging tube will be created afterward of the moving object, but, this false signal is generated as a “pre-ghost” of the object, especially when object moving from the right to the left of the screen. It is a very unnatural phenomenon.

Figure 4-2-2 shows the flash band. When the instantaneous shiny object, like a camera flash, it creates a defect which is generated the light leakage in the capacitor during its read wait time.

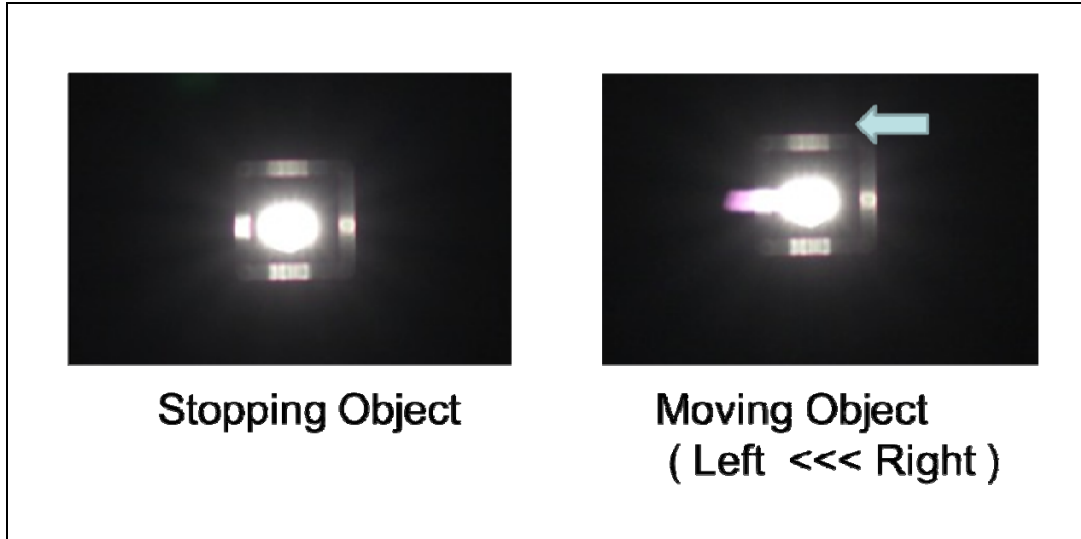

Figure 4-2-1. Phenomenon 1 by Global Shutter

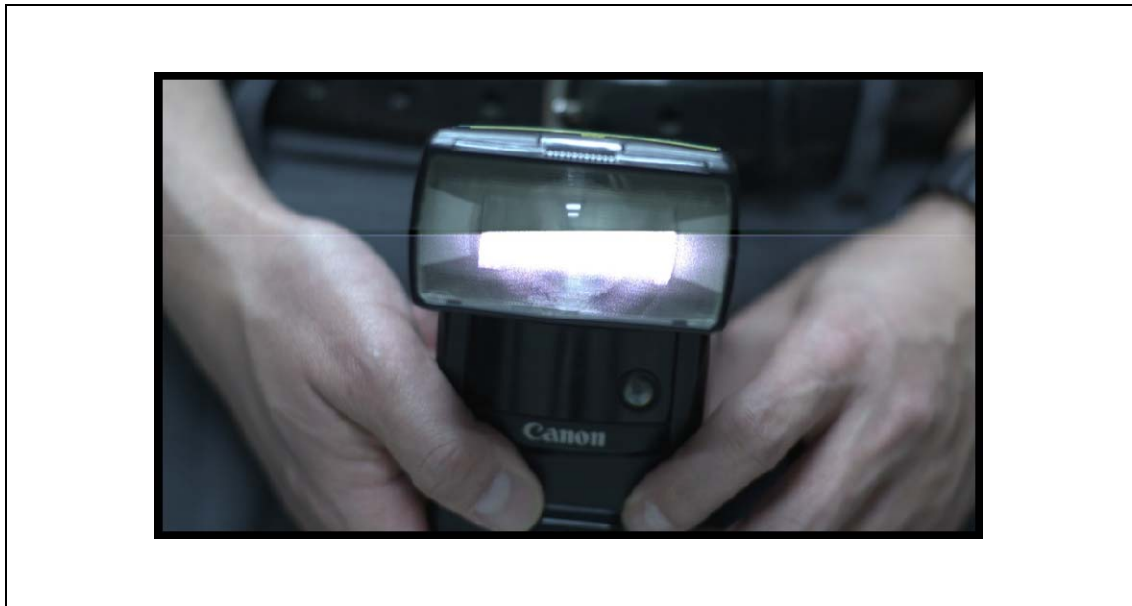

Figure 4-2-2. Phenomenon 2 by Global Shutter

As described above, the global shutter structure being currently commercialized, compared with more highly developed conventional rolling shutter structure, it deteriorates the basic performances such as the S/N ratio, the Dynamic Range, also may create the unnatural phenomenon when shooting a high-luminance subject, it is not yet perfected.

For these reasons, the image sensor that was developed for the VariCam35 uses an advanced and high speed readout rolling shutter structure. In particular, we are employing this structure to achieve the most important factors, the image performance and high-speed operation in the of image production field.

## 5. Conclusion

Panasonic has developed a new super35mm MOS image sensor. The image sensor has the High Pixel count of 4K, Wide Dynamic Range, High Sensitivity, and High S/N ratio, and further can achieve High Speed Operation of 120fps at 4K.

The 4K camera/recorder "VARICAM 35" using this image sensor, is expected to provide the best video quality required 4K production field by the video creators around the world.